

# Keystone Aerial Surveys

Northeast Phil. Airport Phil. PA. \* P.O. Box 21059 Phil. PA. 19114 \* (215) 677-3119 \* FAX (215) 464-2889

## N3444Q GPS ANTENNA INSTALLATION

In preparation for mounting the GPS antenna, the aircraft was flown in a normal photo configuration and attitude. At this point the stabilized camera mount was switched on and allowed to find level. The mount was then "caged" so the camera to aircraft orientation would be preserved. After returning to base the aircraft was placed on jacks. Jacking the aircraft to bring the camera 30sec spherical level back to a level indication reproduced the flight configuration.

A flash plate from this camera with the intersection of the fiducials marked was then placed on the camera film plane with the fiducial marks realigned to the camera. Using a vertical laser plumb a mark was then made on the aircraft upper skin to mark the location of the antenna phase center directly above the fiducial intersection.

A Sensor Systems FAA approved L1/L2 GPS antenna was installed at this location ensuring the phase center was horizontally placed at the predetermined location. While still on the jacks the antenna stand off was machined so the antenna base plate was also level and parallel to the camera film plane.

Before performing the survey to establish the physical relationship between the camera and antenna the previously described flight and orientation procedures were again performed. The physical survey was then conducted, please refer to the accompanying report.

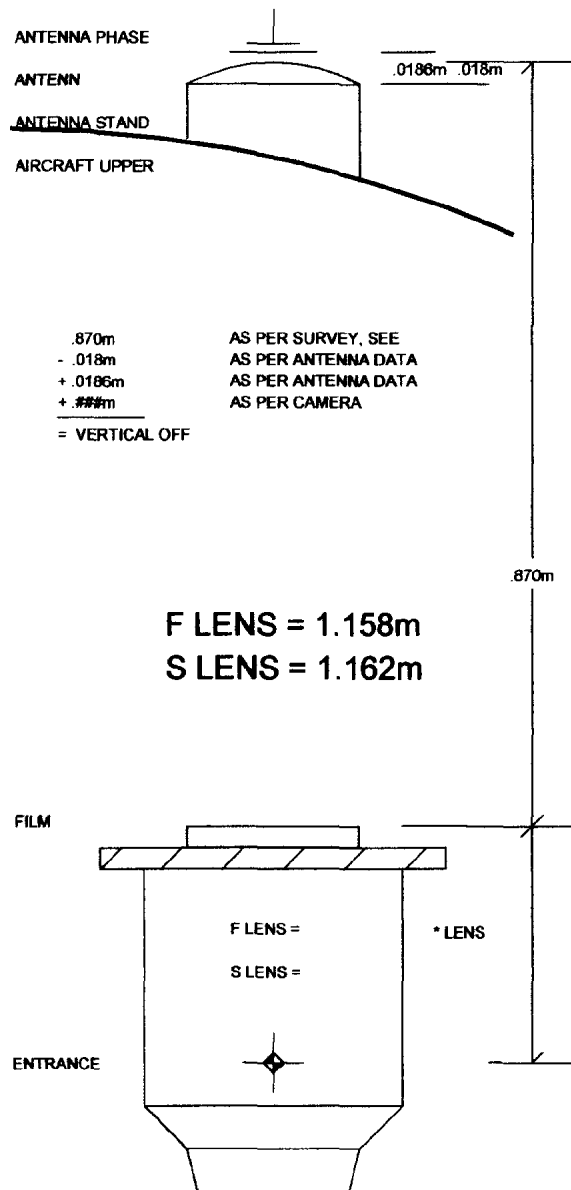

December 12, 2001

Keystone Aerial Surveys, Inc.  
Northeast Philadelphia Airport  
Philadelphia, Pennsylvania 19114

Attn: Mr. Ron Slonaker

Re: Measurement Report

GEOD Corporation was retained by Keystone Aerial Surveys, Inc. to determine the horizontal and vertical offset of the GPS antenna mounted on the exterior of aircraft No. N3444Q from the film plane of the Leica RC30 photogrammetric camera (Serial Number 5297) mounted within. The purpose of this report is to document the procedures used and present the final results of the combined measurements.

Upon arrival at Keystone's hangar, GEOD personnel determined the best orientation of the aircraft to facilitate the measurements. Keystone personnel then jacked the aircraft into the predetermined normal flight attitude. Measurement points were marked and numbered on the exterior of the aircraft. A point in the center of the vent in the nose (point number 201) and a point on top of a fin at the base of the rudder (point number 202) were selected to define the Y measurement axis. A screw in a similar position on each wing tank (point number 203 starboard side and point number 204 port side) was selected to define the X measurement axis. The screws securing the GPS antenna to the exterior of the plane (point numbers 205 through 208) were numbered beginning with the nose side screw and proceeding clockwise. On the camera inside the aircraft, the four holes through which the center fiducial marks are projected (points 209 through 212) were numbered beginning with the forward hole and proceeding clockwise.

The first measurements made were between the camera fiducial marks. Using an Alvin engineers scale graduated to a half millimeter, the distance between adjacent and opposite fiducial marks was measured. The same measurements were made between the screws on the GPS antenna.

Next, three observation points (point numbers 1 through 3) were set up around the aircraft to collect the measurements that would determine the relative horizontal position of the aircraft, the camera, and the GPS antenna. All the points on the camera could be observed from both points 1 and 2. All the exterior points could be observed from points 1 and 2, Point 3 could only observe point number's 201(nose point) and 204(port wing point). These measurements were made using a Topcon GTS-300 total station. This instrument's angular accuracy is specified at "1 second standard deviation based on DIN18723" and it's distance accuracy is specified at "+/- 2 mm + 2 ppm". All distance measurements were made using the instruments internal EDM to a mini-prism assembly placed on the measurement point.

Finally, measurements were made to determine the vertical offset of the GPS antenna from the camera film plane. First, a spot on the hangar floor near the location of the GPS antenna was

marked. Using a carpenter's level and a Lufkin steel rule graduated in millimeters, the distance from the top of the dome of the antenna to the mark on the hangar floor was measured. A Zeiss NI-2 automatic level was then employed to level from the mark on the hangar floor to each of the camera fiducial marks. An engineer's scale was then used to measure from the top dome of the GPS antenna to each of the screws.

All of these physical measurements were then combined into a least squares adjustment. The point on the tail (point number 202) was assigned the horizontal coordinate of (0,0). The forward fiducial mark (point number 209) was assigned the elevation of 0. The direction from the tail point to the nose point (point number 201) was set as the positive Y axis. Additionally, the angles between adjacent fiducial marks and GPS antenna screws were constrained to be close to 90 degrees. The adjustment resulted in standard deviations for the camera and antenna points of approximately 1.5 mm. The full results can be viewed in the included copy of the adjustment output listing.

The final horizontal position of the center of the film plane (point number 300) and the center of the GPS antenna (point number 301) were computed by mathematically intersecting the opposite measurement points on each. The final vertical position of the film plane was computed by averaging the vertical position of each fiducial mark. The final vertical position of the top of the dome of the antenna was taken from the level adjustment.

Based on these observations, the center of the film plane is 0.0039 M to port, 0.0075 M forward, and 0.8695 M below the top center of the dome of the GPS antenna.

Please note that the final position of the camera film plane (point 300) is the mathematical intersection of the holes through which the center fiducial marks are projected. The user of these observations should consult with the manufacturer's published camera geometry to relate these observation locations to camera geometry such as the "entrance node" and/or the "rear node" needed for airborne GPS computations. Also, the final position of the GPS antenna (point 301) is the center of the antenna at the top of the dome. The L1 & L2 phase center relationship to this point is to be determined by separate observations.

Sincerely,

GEOD Corporation

Joseph B. Priestner, PE & PLS  
Project Manager

**Final Coordinates**  
**Project: 99-1608**  
**Client: Keystone Aerial Surveys**

**GEOD Corporation**  
**November 27, 2001**

Point	X Coordinate (Meters)	Y Coordinate (Meters)	Elevation (Meters)	Description
1	4.4310	11.2509	-1.3991	X-MARK
2	6.2381	-1.6756	-1.4069	X-MARK
3	-7.2897	6.4846	-1.4205	X-MARK
201	0.0000	7.9237	0.0876	NOSE
202	0.0000	0.0000	0.3771	TAIL
203	5.4219	6.6530	0.3705	WING
204	-5.4374	6.6293	0.3493	WING
205	-0.2599	4.3169	0.8639	GPS-SCREW
206	-0.2234	4.2854	0.8636	GPS-SCREW
207	-0.2549	4.2489	0.8639	GPS-SCREW
208	-0.2914	4.2803	0.8640	GPS-SCREW
209	-0.2651	4.4001	0.0000	CAM-PT
210	-0.1517	4.2942	-0.0009	CAM-PT
211	-0.2576	4.1808	-0.0009	CAM-PT
212	-0.3710	4.2867	-0.0003	CAM-PT
300	-0.2613	4.2904	0.0005	CENTER FILM PLANE
301	-0.2574	4.2829	0.8700	CENTER GPS ANT @ TOP DOME

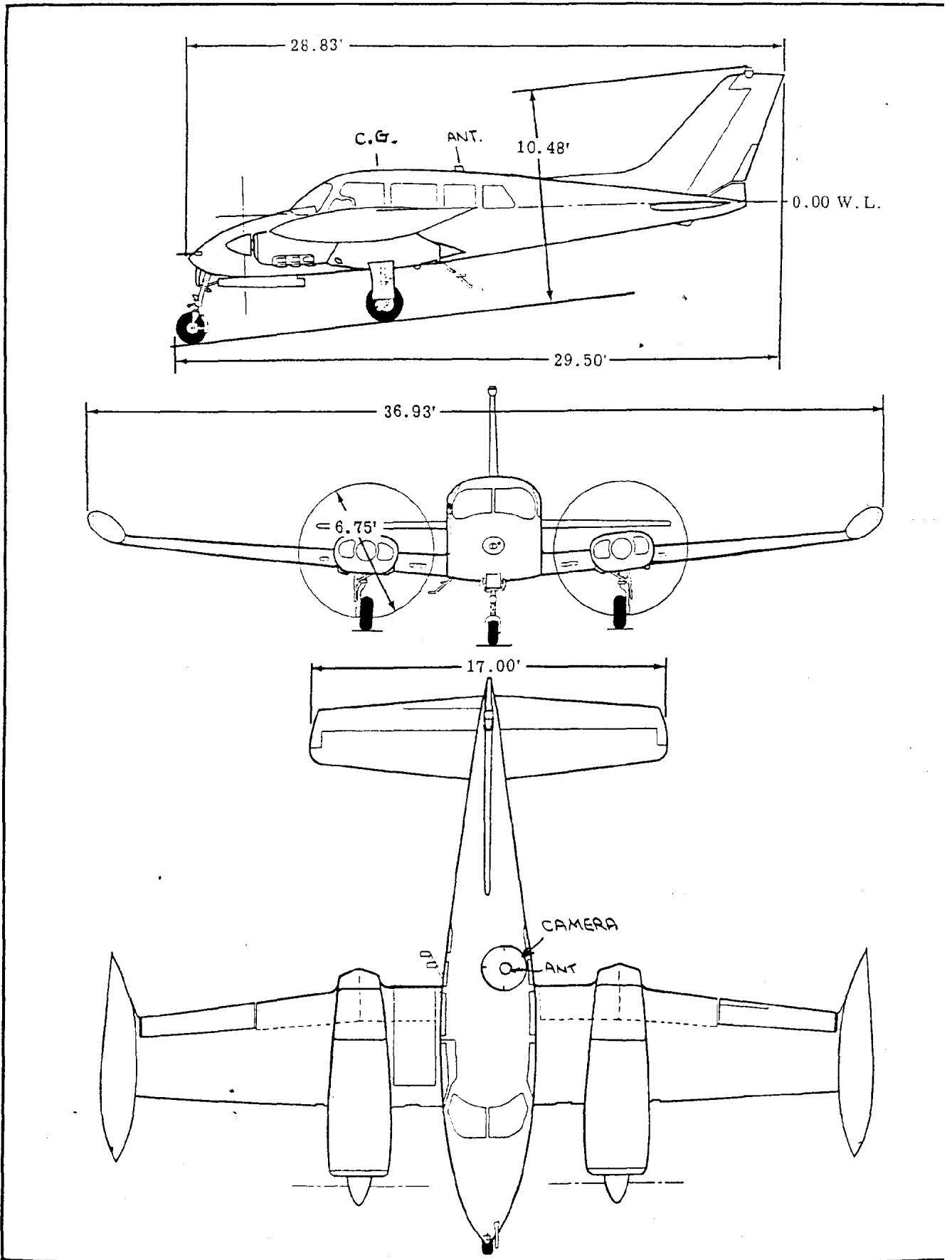
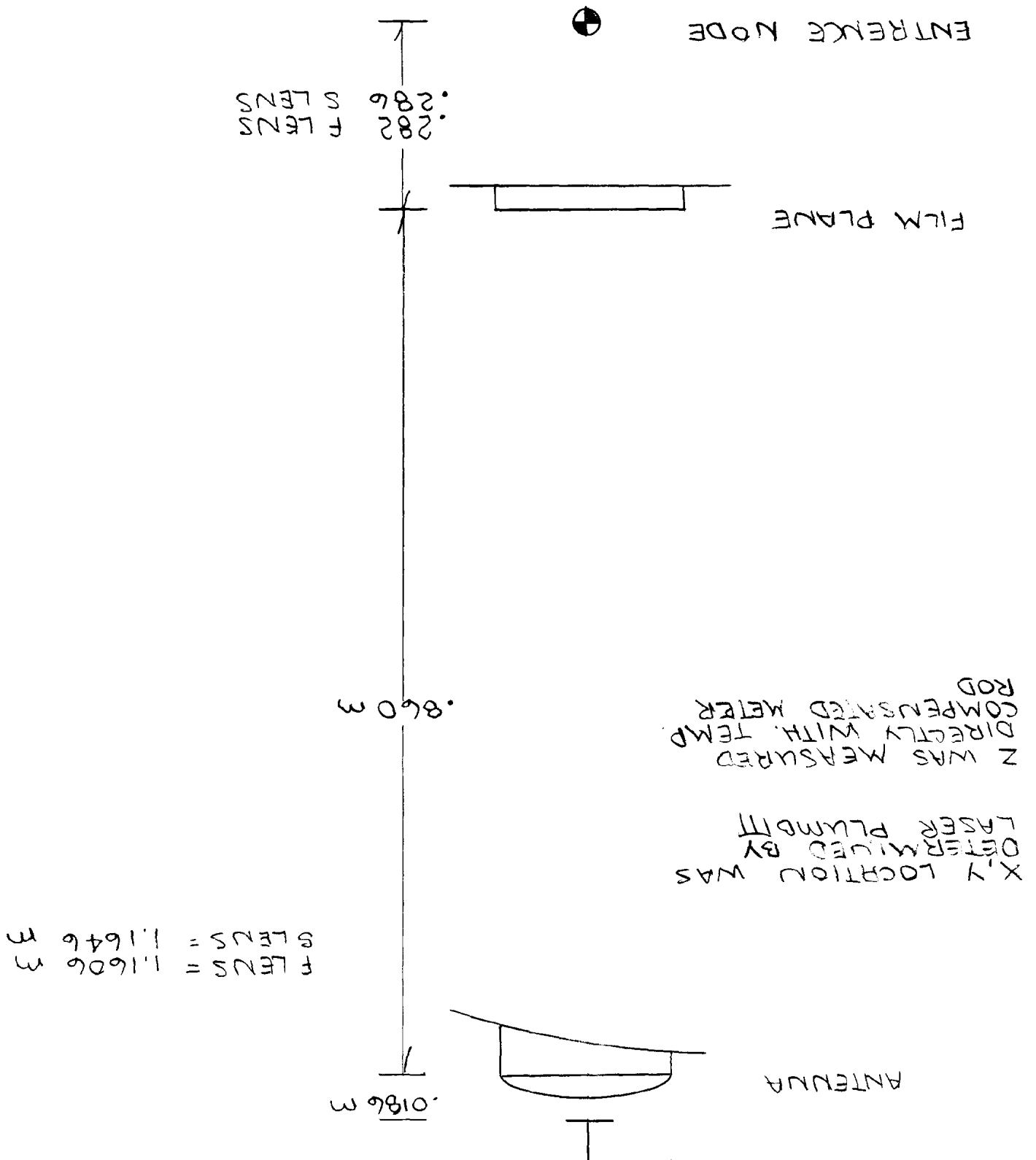

Figure 1-1C. Three-View 320C Aircraft (Model 1965)



ENTRANCE NODE

.282 F LENS S LENS

FILM PLANE

.860 m

Z WAS MEASURED DIRECTLY WITH TEMP COMPENSATED METER ROD

X, Y LOCATION WAS DETERMINED BY LASER PLUMBIT

ANTENNA

.0186 m

F LENS = 1.1606 m  
S LENS = 1.1646 m